

Centrifugal Utility Fans Model USFD-100

- Direct Drive



BUILDING VALUE IN AIR.



June
2018

Efficiency – Controllability – Simplicity

The USFD-100 is a direct drive model with a backward-inclined centrifugal wheel. The housing is constructed from galvanized steel with a bolted frame. High performance powder coating is optional. Fans are provided with integral speed control for easy system balancing. Simplified wiring and preprogrammed variable frequency drive (3-phase) make installation quick and easy.

Standard Construction and Configuration

- Volume up to 6,500 CFM
- Static pressure up to 3 in. wg
- Galvanized or coated steel
- Greenheck's Permalock™ lock seam scroll
- Aluminum, centrifugal backward inclined wheel
- NEMA-3R, toggle switch, mounted and wired
- Bolted access door
- Weatherhood
- Drain

Accessories

- Inlet guard
- Outlet flange
- Outlet guard
- Backdraft gravity damper
- Neoprene isolators
- Equipment supports
- Extended warranty



Simplified Wiring

Easy to install – featuring a terminal strip, disconnect and speed control mounted and wired by the factory.

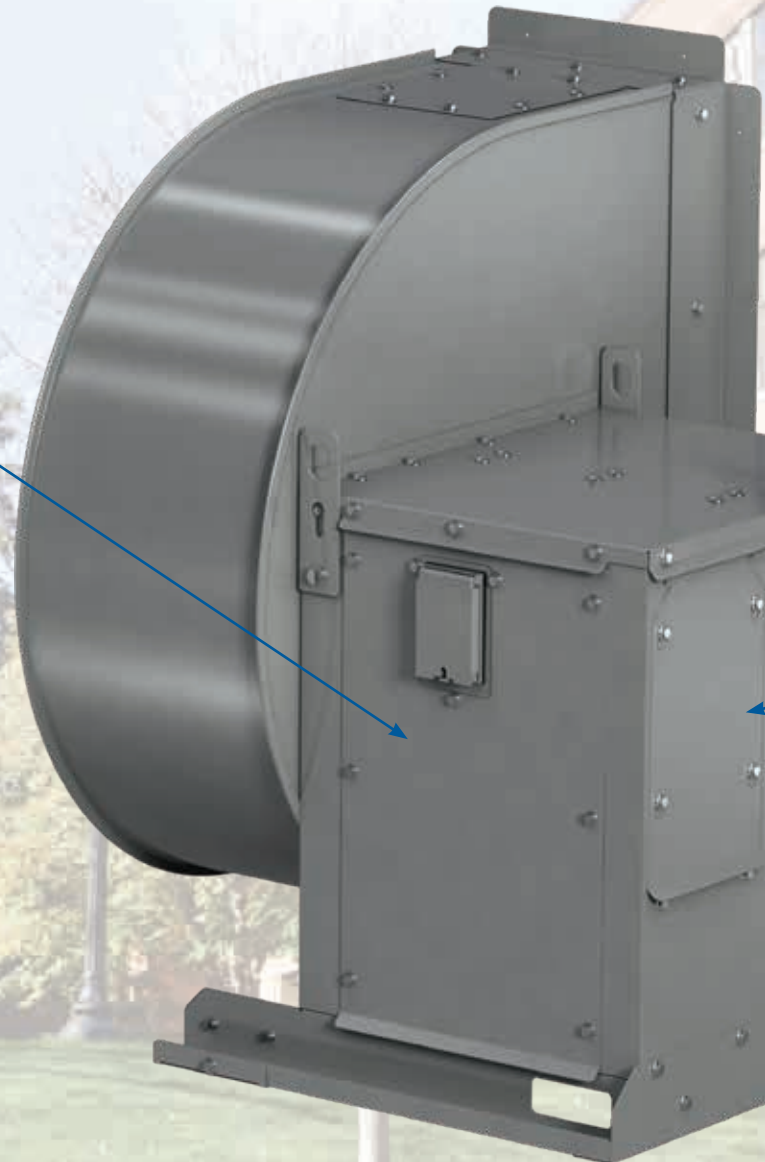

AMCA certified data may be found
in Greenheck's Computer Aided
Product Selection Program (CAPS)



UL/cUL 705 Listed Power Ventilator
File #E40001



Direct Drive Motor
Low maintenance – no belts, bearings or pulleys to service.

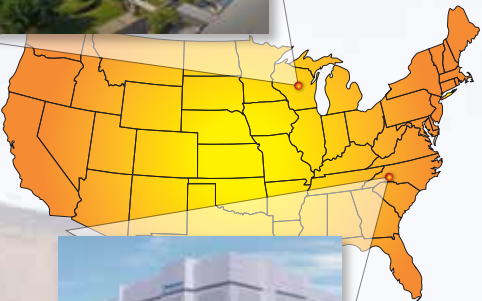

Quick Build Availability

Model USFD-100 fans are available in as little as 5 days on our Quick Build program. Quick Build offers you a number of lead times to meet your needs.



Integrated Speed Control

Speed control is mounted, wired and programmed at the factory. Adjust fan speed with a push of a button.

Single-phase applications use Greenheck's electronically commutated (EC) Vari-Green® motor with a control dial for adjustment.

Three-phase applications use a NEMA Premium Efficient motor with variable frequency drive (VFD).

1-phase and 3-phase options can be controlled via 0-10 vDC signals.

Model Number Code

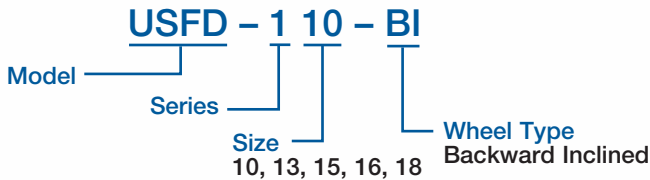

Design and Selection Support

Enjoy Greenheck's extraordinary service, before, during and after the sale.

**QUICK
DELIVERY**



CAPS



Greenheck
GREEN
Supporting Green Building
Initiatives Worldwide



Greenheck offers added value to our wide selection of top performing, energy-efficient products by providing several unique Greenheck service programs.

- Our **Quick Delivery** Program ensures shipment of our in-stock products within 24 hours of placing your order. Our **Quick Build** made-to-order products can be produced in 1-3-5-10-15- or 25 day production cycles, depending upon their complexity.
- Greenheck's free **Computer Aided Product Selection** program (CAPS), rated by many as the best in the industry, helps you conveniently and efficiently select the right products for the challenge at hand.
- Greenheck has been **Green** for a long time! Our energy-saving products and ongoing corporate commitment to sustainability can help you qualify for LEED credits.
- Our **3D service** allows you to download at no charge, lightweight, easy-to-use AutoDesk® Revit® 3D drawings for many of our ventilation products.

Find out more about these special Greenheck services at greenheck.com



Building Value in Air

Greenheck delivers value to mechanical engineers by helping them solve virtually any air quality challenges their clients face with a comprehensive selection of

top quality, innovative air-related equipment. We offer extra value to contractors by providing easy-to-install, competitively priced, reliable products that arrive on time.

And building owners and occupants value the energy efficiency, low maintenance and quiet dependable operation they experience long after the construction project ends.

Our Commitment

As a result of our commitment to continuous improvement, Greenheck reserves the right to change specifications without notice.

Specific Greenheck product warranties are located on greenheck.com within the product area tabs and in the Library under Warranties.



Prepared to Support
Green Building Efforts

